



Pedestal System

www.fixplus.com.tr





Raised Floor System

Excellent Solution
For Indoor and
Outdoor Areas

Fixplus Supports can be applied in both indoor and outdoor places offer effective solutions in different social domains by providing an easy tiling opportunity as well as being highly resistant to breakage.

Fixplus Supports prove their quality with well-selected raw material, the features of resistance to severe and harsh environment conditions which taken into account in design and also compliance with production standards.

They are indivisible parts of raised floor applications with thick tiles in 20mm and suited for all kinds of tiling materials such as wood, natural stone, ceramics, composite materials, metal and fiberglass depending on accessories which can be integrated. By this way, they provide opportunities to make unique designs in different of areas.

Thanks to its high technical capacity, it is ideal for private and public areas. It can be used safely in places such as terraces, balconies, rooftops, sun lounges, verandas, swimming pool areas, parks, villas, gardens, information processing centers, distribution companies, call centers, education facilities where intense human traffic is available.



What are the advantages?











An empty usage area is obtained between ground level and surface floor . In indoor applications such as residence and working places this area ensures the capability of laying and controlling lighting systems, cables and pipes easily.

In outdoor applications can be obtained joint gaps between tiles ranging from 2 mm up to 4mm which facilitate rainwater disposal so fast.

Increases sound and heat insulation while it is easily applied on slopping and imperfect surfaces. There is no need for a foreman who is expert in tiling in order to apply the system. Installation is easy and fast.

Made from 100% eco-friendly material.

Withstand extreme weather conditions within temperature ranging from -40° to +80°.

 <p>They avoid the appearance of pipes and cables</p>	 <p>They absorb structural moves and avoid deformations</p>	 <p>Less weight in buildings</p>	 <p>Leveling operation is much easier and healthier</p>	 <p>Fast application and saving on time</p>
 <p>Fast water drainage</p>	 <p>Faster and easier heat flow</p>	 <p>High strength against breakage</p>	 <p>Sound isolation</p>	 <p>Ecologically Clean</p>

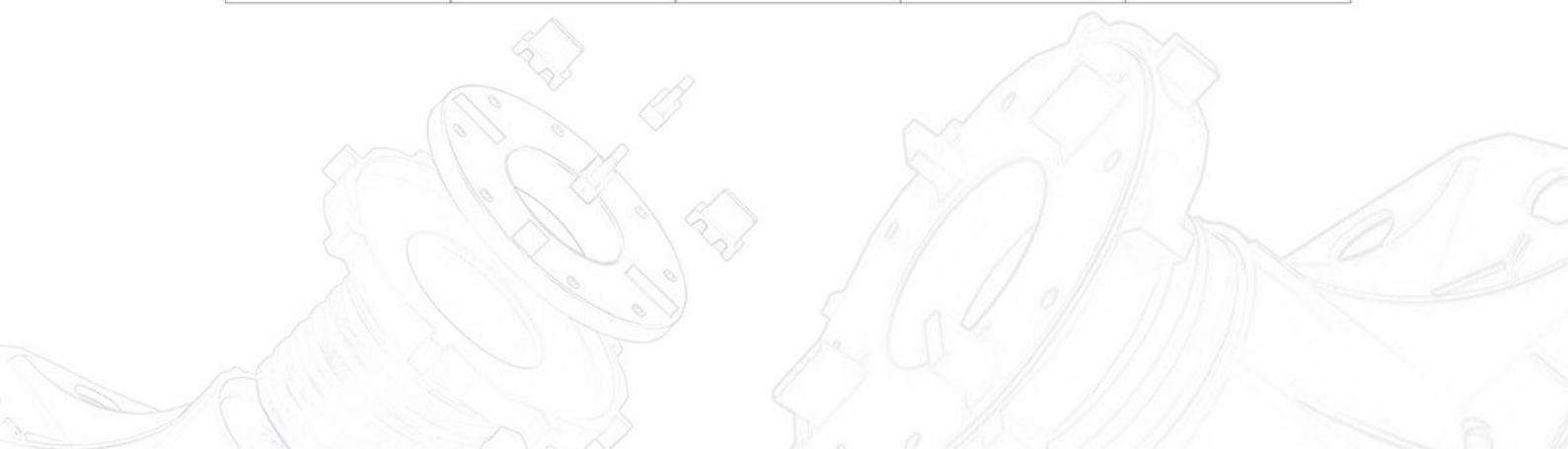

Basic Series



Basic Series **Supports** can be used to create raised floors at varying heights from 32mm up to 250mm on flat or sloped surfaces.



BS60

Used in tiling applications to create raised floors with natural stone, ceramic and composite flooring materials.



BSW60

Applied with wood or aluminum joists to install raised floors from wooden and composite deck flooring materials.



SL60

Used with self-levelling system in tile applications for raised floors. Allows auto slope correction on surfaces maximum up to 5% gradient.



SLW60

Used in raised floor applications with self-levelling system through wood and aluminum joists. By this way, wooden and composite deck flooring materials can be installed easily. Allows auto slope correction on surfaces maximum up to 5% gradient.



BS60

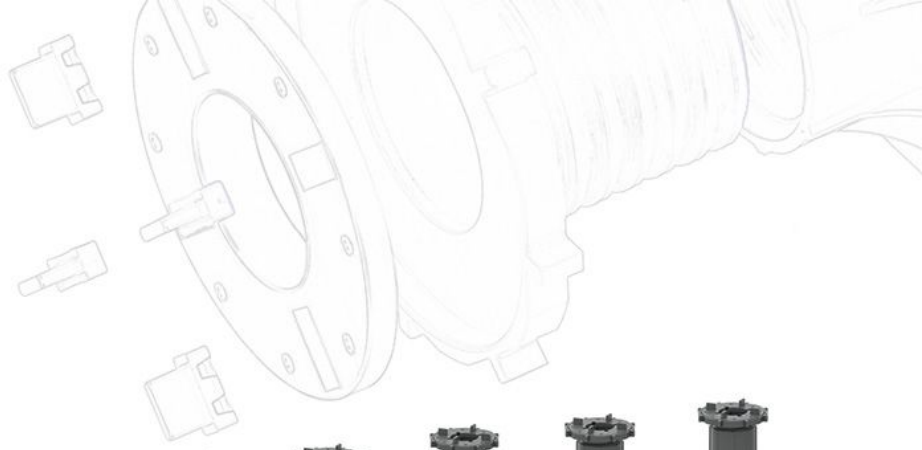

BS60-01
(32-38mm)



BS60-02
(38-50mm)



BS60-03
(50-75mm)



BS60-04
(73-110mm)



BS60-05
(102-130mm)



BS60-06
(126-155mm)



BS60-07
(147-184mm)



BS60-08
(175-205mm)



BS60-09
(200-225mm)



BS60-10
(220-250mm)



BSW60



BS60W-01
(32-38mm)



BS60W-02
(38-50mm)



BS60W-03
(50-75mm)



BS60W-04
(73-110mm)



BS60W-05
(102-130mm)



BS60W-06
(126-155mm)



BS60W-07
(147-184mm)



BS60W-08
(175-205mm)



BS60W-09
(200-225mm)



BS60W-10
(220-250mm)



SL60



SL60-01
(42-48mm)



SL60-02
(48-60mm)



SL60-03
(60-85mm)



SL60-04
(83-120mm)



SL60-05
(112-140mm)



SL60-06
(136-165mm)



SL60-07
(157-194mm)



SL60-08
(185-215mm)



SL60-09
(210-235mm)



SL60-10
(230-260mm)



SLW60



SLW60-01
(42-48mm)



SLW60-02
(48-60mm)



SLW60-03
(60-85mm)



SLW60-04
(83-120mm)



SLW60-05
(112-140mm)



SLW60-06
(136-165mm)



SLW60-07
(157-194mm)



SLW60-08
(185-215mm)



SLW60-09
(210-235mm)



SLW60-10
(230-260mm)



BS60

BS60 Supports can be used to create raised floors at varying heights from 32mm up to 250mm on flat or uneven surfaces.

Our products are made from 100% eco-friendly raw materials and do not contain any harmful chemicals to environment.

Withstand extreme weather conditions within temperature ranging from -40° to $+80^{\circ}$.

In the applications of BS60 Serie, it is recommended to use a fifth support at the center of the tile to ensure to distribute the load equally.

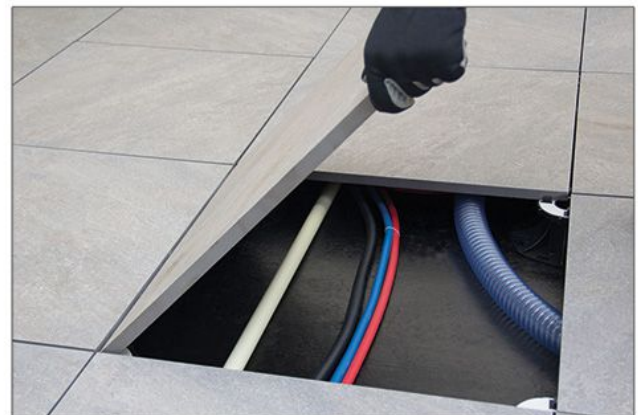



BSW60

BSW60 Supports are applicable to wooden and composite deck flooring materials.

BS60 can be easily converted into BSW60. By making the tabs taken out from their holes and putting the parallel connecting part WC9801 instead of them BS60 will be changed into BSW60. Wooden or aluminum floor joists can be fixed to parallel connecting part WC9801 to create the required flooring frame work on the ground on which the installation materials can be applied.

BSW60 Series Supports can be used to create raised floors at varying heights from 32mm up to 250mm on flat or uneven surfaces.

Can be used safely in places such as terraces, balconies, rooftops, sun lounges, verandas, swimming pool areas, parks, villas where intense human traffic is available.



Maxi Series

The Supports of Maxi Series designed to create elevated floors at varying heights from 75mm up to 540mm on flat or uneven surfaces.

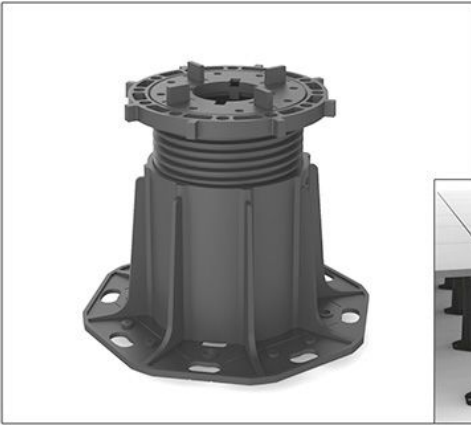

BS110

Used in tiling applications to create raised floors with natural stone, ceramic and composite flooring materials.



BSW110

Applied with wood or aluminum joists to install raised floors with wooden and composite deck flooring materials.



SL110

Used with self-levelling system in tile applications of raised floors. Allows auto slope correction on surfaces maximum up to 5% gradient.



SLW110

Used in raised floor applications with self-levelling system through wood and aluminum joists. By this way, wooden and composite deck flooring materials can be installed easily. Allows auto slope correction on surfaces maximum up to 5% gradient.



BS110



BS110-04
(75-125mm)



BS110-05
(120-170mm)



BS110-06
(170-218mm)



BS110-07
(214-262mm)



BS110-08
(263-312mm)



BS110-09
(307-356mm)



BS110-10
(357-405mm)



BS110-11
(400-450mm)



BS110-12
(450-500mm)



BS110-13
(495-543mm)



BSW110



BSW110-04
(82-131mm)



BSW110-05
(125-175mm)



BSW110-06
(175-224mm)



BSW110-07
(219-270mm)



BSW110-08
(270-319mm)



BSW110-09
(313-362mm)



BSW110-10
(363-413mm)



BSW110-11
(407-455mm)



BSW110-12
(456-506mm)



BSW110-13
(500-550mm)



SL110



SL110-04
(85-135mm)



SL110-05
(130-180mm)



SL110-06
(180-228mm)



SL110-07
(224-272mm)



SL110-08
(273-322mm)



SL110-09
(317-366mm)



SL110-10
(367-415mm)



SL110-11
(410-460mm)



SL110-12
(460-510mm)



SL110-13
(505-553mm)



SLW110



SLW110-04
(85-135mm)



SLW110-05
(130-180mm)



SLW110-06
(180-228mm)



SLW110-07
(224-272mm)



SLW110-08
(273-322mm)



SLW110-09
(317-366mm)



SLW110-10
(367-415mm)



SLW110-11
(410-460mm)



SLW110-12
(460-510mm)



SLW110-13
(505-553mm)



BS110

BS110 Supports are used to create raised floors at varying heights from 75mm up to 540mm on flat or uneven surfaces.

Can be obtained auto surface correction on sloped surfaces maximum up to 5% gradient in order to be used with SLC001 self-levelling head.

Our products are made from 100% eco-friendly raw materials and do not contain any harmful chemicals for environment.

Withstand extreme weather conditions within temperature ranging from -40° to +80°.

Recommended the extension parts should be tightened up before they are installed.

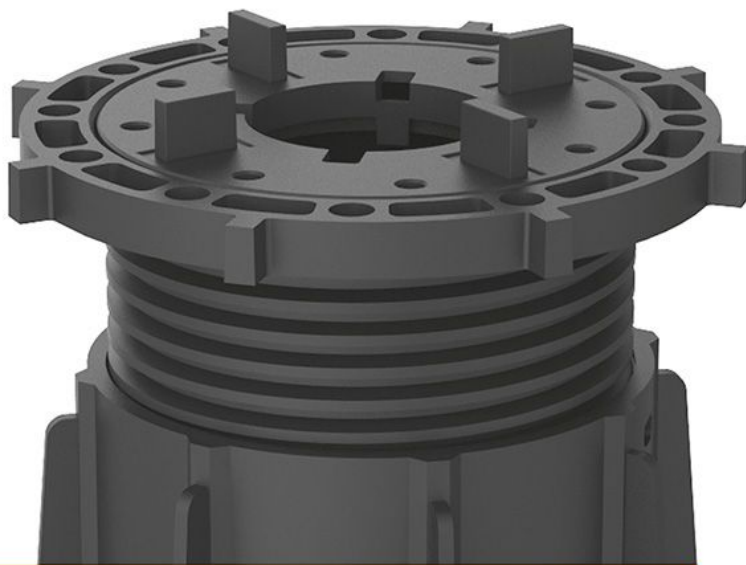

54cm Maxi

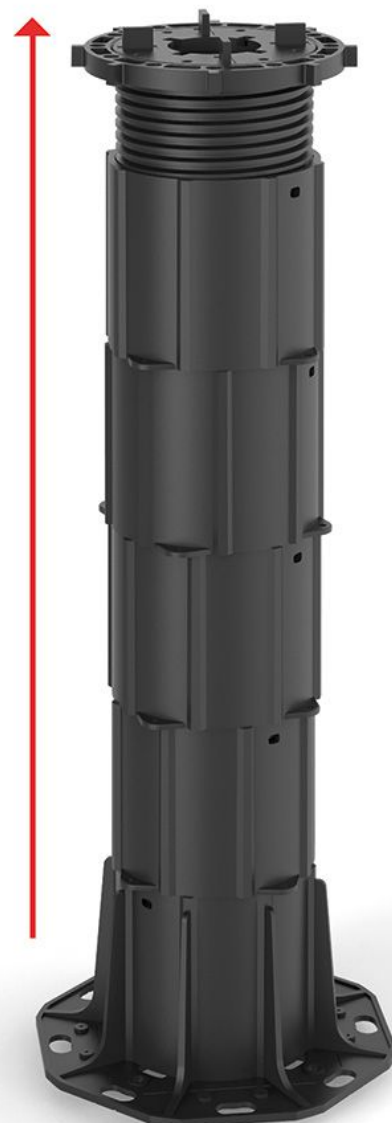



BSW110

BSW110 Supports are applicable to wooden and composite deck flooring materials. Compared with basic series supports BSW110 is preferred to make floors more elevated and withstand heavier loads.

Thanks to W14002 adjustable connecting part can be installed floor joists in required thickness.

Thus, wooden or aluminum floor joists can be fixed to the supports and get a required flooring frame work on which the installation materials will be applied.

BSW110 Supports can be used to create raised floors at varying heights from 75mm up to 540mm on flat or uneven surfaces.

Can be used safely in places such as terraces, balconies, rooftops, sun lounges, verandas, swimming pool areas, parks, villas where intense human traffic is available.



Maximum Eğim
%5

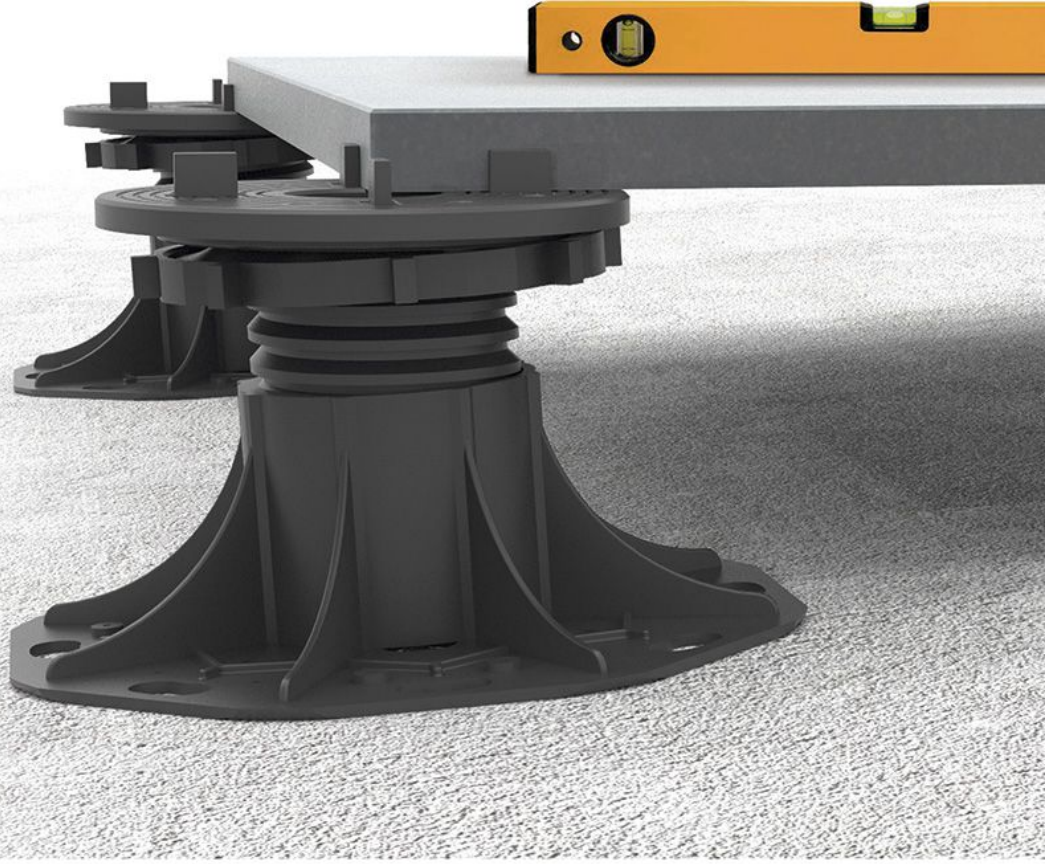

SLC001

SLC001 is a Self-Levelling System which modular and compatible with Basic and Maxi Series. It is used fixing on modules and allows auto surface correction on sloped surfaces maximum up to 5% gradient. With 360° rotatable design it helps also to find the slope direction.

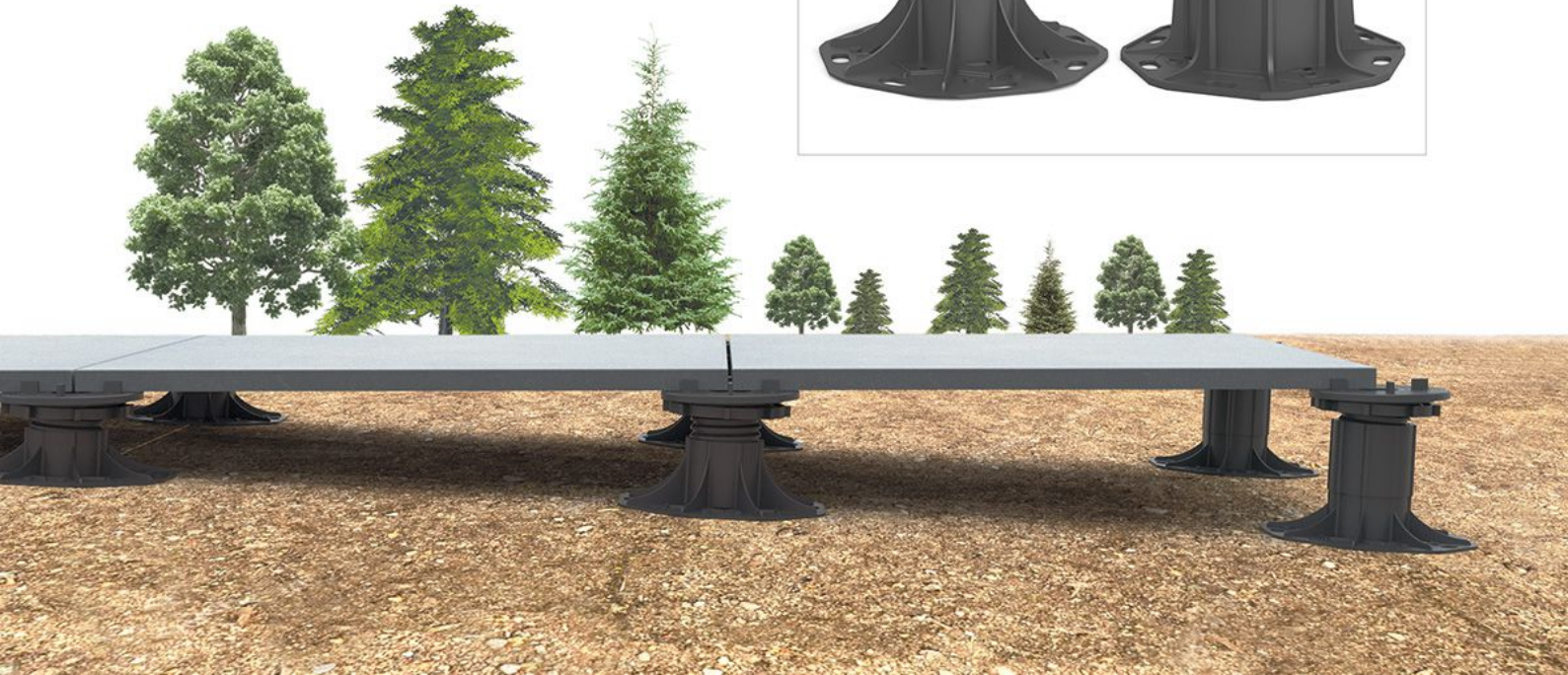



Lateral Flooring Installation

Lateral installation can be applied with a support and a lateral disc.

These accessories allow making lateral surface applications in raised floors. Open lateral surfaces can be easily covered with flooring materials.



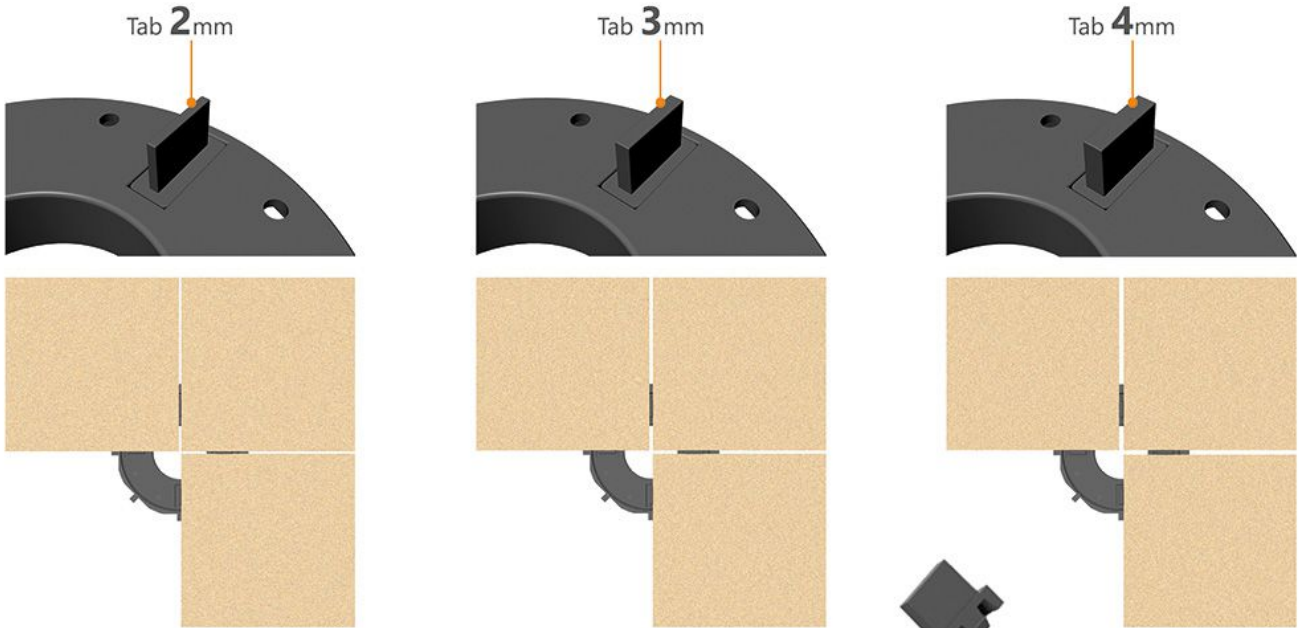

Replaceable Grout Tabs

With all modules of series Basic, Maxi and SP are used same type of tabs. These tabs can be replaced optionally.

They can be taken out from their holes and replaced easily. It is not required to break the tabs on the disc. Thus, the modules can be used with different size of tabs in different places.

In outdoor applications it is recommended to use 4mm of tabs in order to provide rapid rain water drainage.



Adjustment Tool

Designed for Fixplus Supports to arrange easy adjustment. Initial adjustments can be made easily manually during installation, but after installing heavy flooring materials the adjustment process can not be made easily with hands. In that case, the adjustment tool provide ease of adjustment.





Drainage Channels

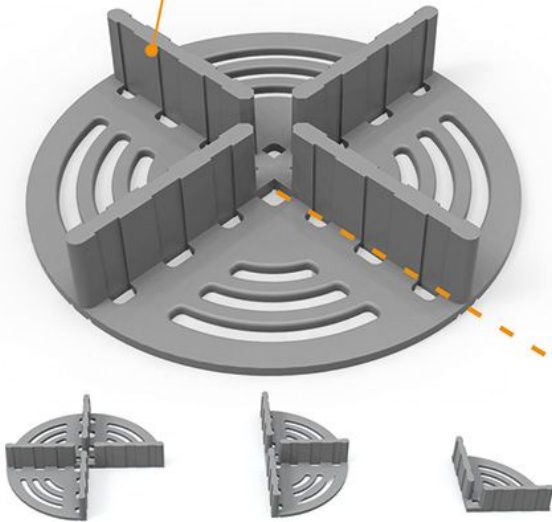

Paving Spacer

Paving spacer ensures a fast ground application on sand, gravel or grass-surfaced parks, gardens and squares.

It facilitates fast and effective application of special ceramics and natural stones on these areas. Thanks to its sensitive joint channel and excellent stability by forming a 3 mm-joint gap it provides an opportunity for fast drainage of water gathered on the ground.

It can be cut so easily and used in 4 different angles by using shearing line on it.

Paving Spacer can be converted to lateral modules by being cut from marked points according to necessity of tiling.

Trim Line

As shown on the left of the pictures the spacer can be converted to lateral modules by being cut from marked point according to necessity of the tiling.

SP10 Flooring Support



Thanks to SP-10 Module it is possible to create raised floors ranging from 10mm up to 30mm high. It is possible to adjust the system easily.

SP-10 Module is augmented within itself at rates ranging from 10 mm to 15 mm high. If required, an additional 5 mm high is obtained by inserting SP-5 plate under SP-10 Module. SP-5 Plate can be mounted on top of each other to increase the elevation.

By using SP-10 Module and SP-5 Plate, can be made raised floor application at rates ranging from 10 mm upto 30 mm high. If it is required more higher elevations than 30 mm BS60 Series must be used instead of that.

They are highly resistant to breakage thanks to their special design and depending on production values.

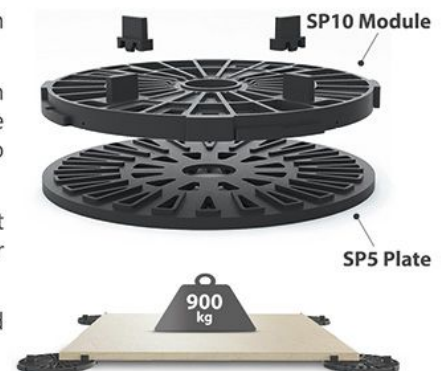



ÖZTÜRK PLASTİK ve KALIP SAN. TİC. LTD ŞTİ.
İkitelli Organize Sanayi Bölgesi Mah. Enkoop Cad. No:4C
Başakşehir / İstanbul -TÜRKİYE
Tlf: +90 212 485 24 53 Fax: +90 212 485 24 21



Certificate No: TR003104-1
Basım Yeri: İnceler Ofset Mat. Amb. San. Tic. Ltd. Şti Basım Tarihi: 07.10.2017